



INDEPENDENT DEVELOPMENT TRUST

ANNEXURE B - CIVIL AND STRUCTURAL DRAWINGS

**TENDERING PROCEDURES, RETURNABLE DOCUMENTS,
AGREEMENT AND CONTRACT DATA, SCOPE OF WORK AND SITE
INFORMATION**

**APPOINTMENT OF A CONTRACTOR FOR THE CONSTRUCTION OF NEW
TECHNICAL WORKSHOPS TO WAGPOS TECHNICAL HIGH SCHOOL FOR THE
DEPARTMENT OF EDUCATION, NORTH WEST PROVINCE.**

BID NO: DOE14NWER014

CLOSING DATE AND TIME: 24th JULY 2023 at 12h00

Independent Development Trust

SCM / Technical Enquiries

E-mail: noxolod@idt.org.za and andrewn@idt.org.za

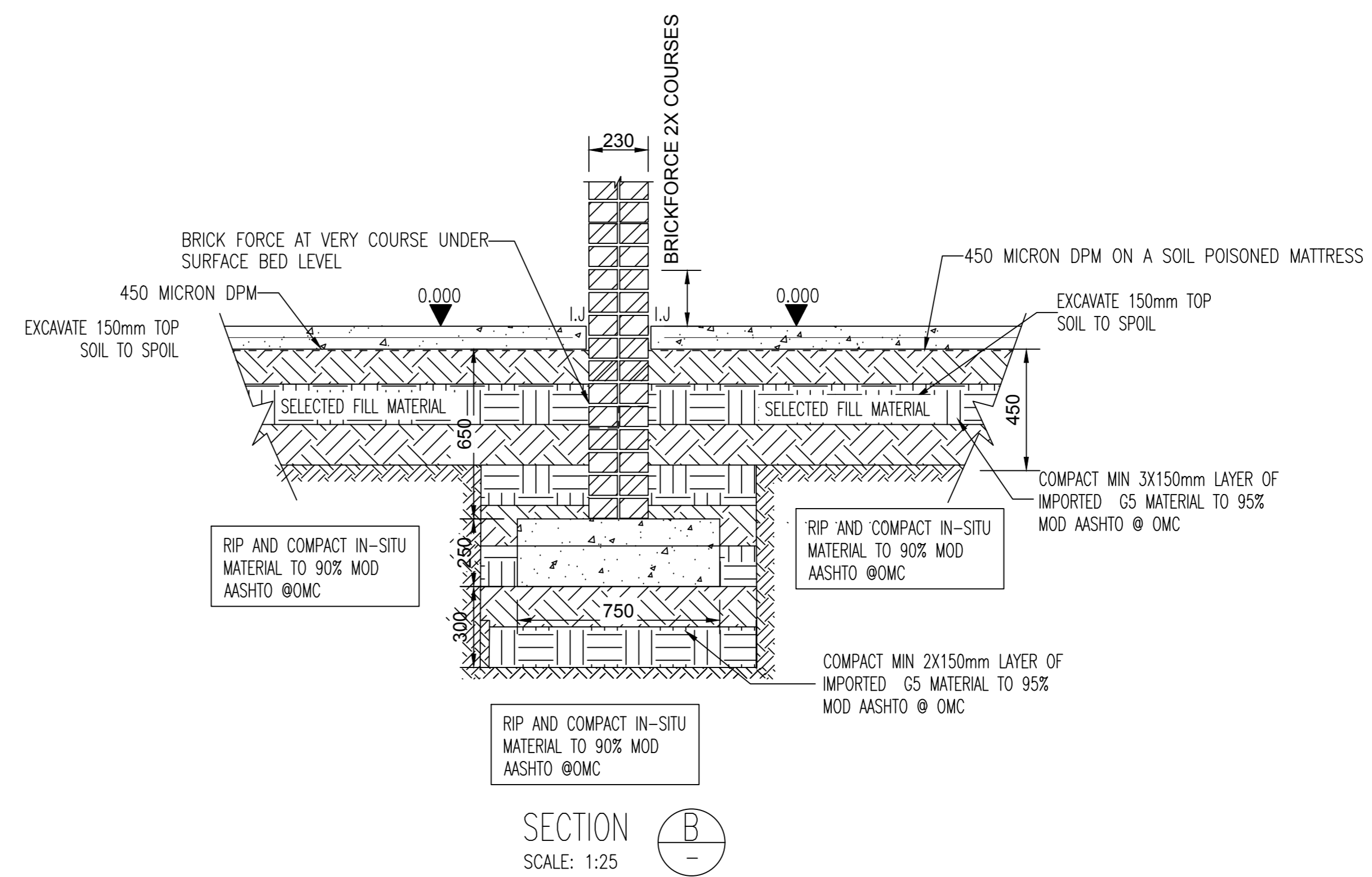
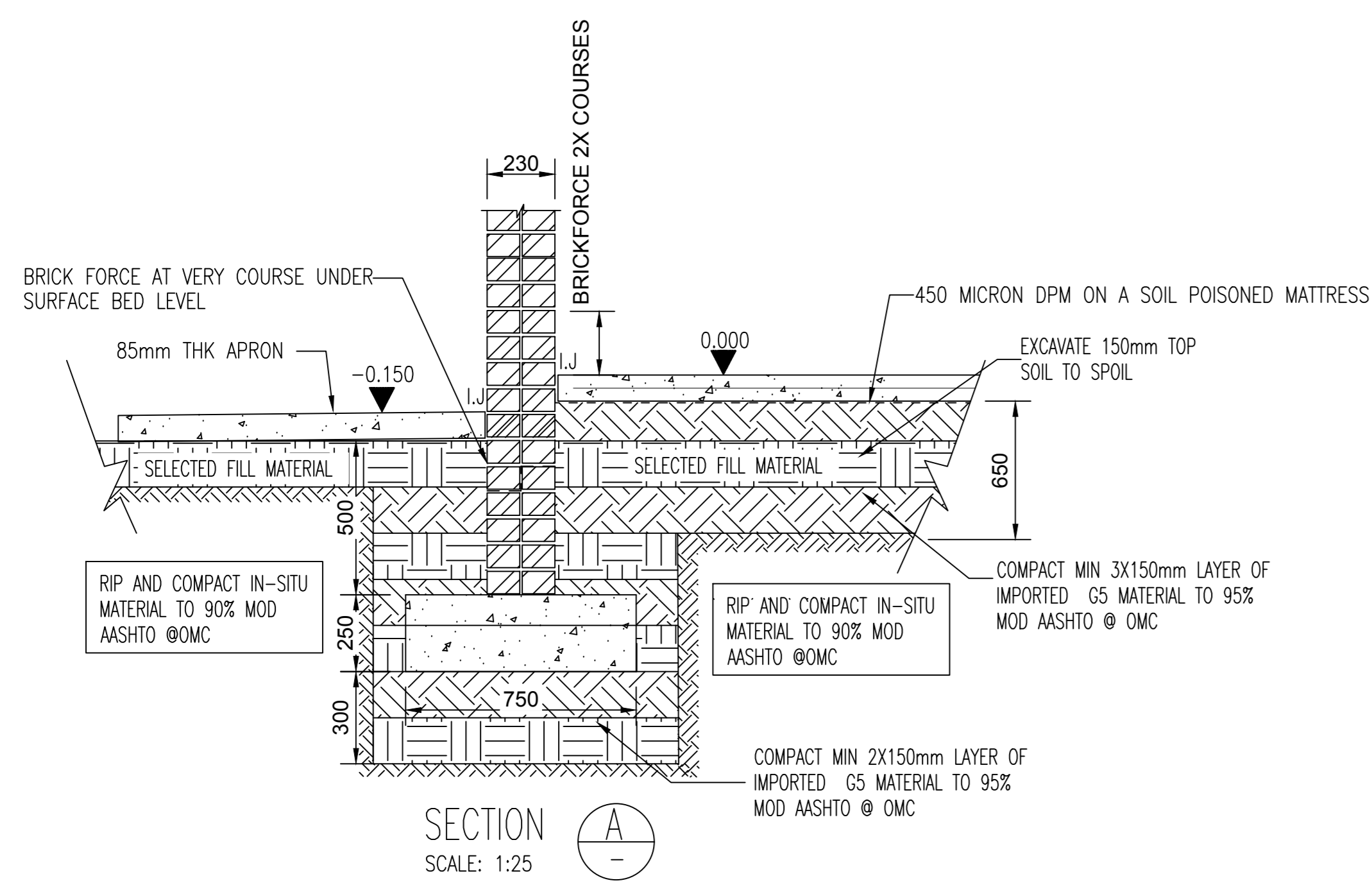
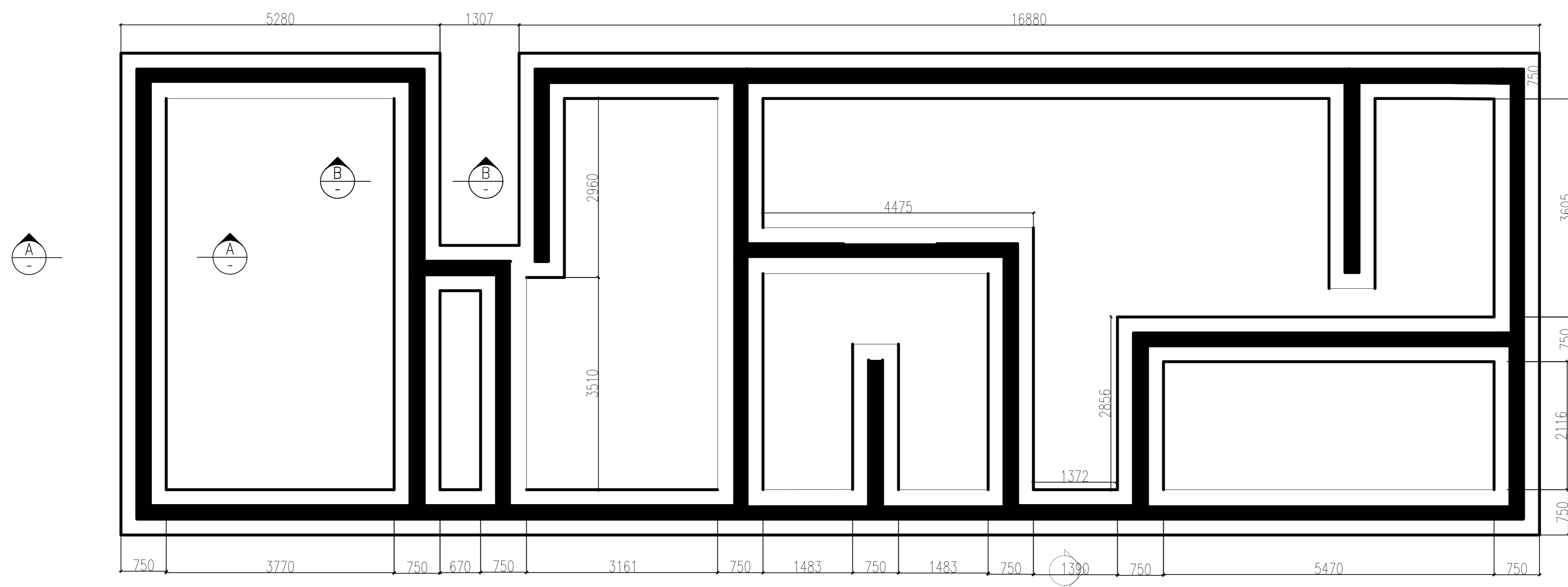

REV No	DATE	ISSUED FOR APPROVAL	DESCRIPTION
A	03/19		
REVISIONS			
SIZE ON ORIGINAL DRAWING 100 mm			
INSTITUTION			
WAGPOS TECHNICAL SCHOOL			
SERVICE DESIGN			
REFURBISHMENT			
BOC	BUILDING / SITE DESCRIPTION	STAGE	
A3	SITE	4	
DISCIPLINE			
STRUCTURAL			
WORK DESCRIPTION - SUB DIVISION			
ADMIN FOUNDATION LAYOUT			
DRAWING DESCRIPTION			
	T.MATSEKE	DRAWN	
	T.MATSEKE	CHECKED	
	M.NYAMALINDURU		
DATE	RESPONSIBLE PROFESSIONAL - DESIGN NAME	SIGNATURE	PR NUMBER
22/10/2019	R. SUKHLAL		200370162
	RESPONSIBLE PROFESSIONAL - CO-ORDINATION		
22/10/2019			200370162
CONSULTANT :			
CONTRACTOR :			
CAD SYSTEM	AUTOCAD	962-S1-ST-C-001-A	FILE NAME
SIZE			REV
A1			A

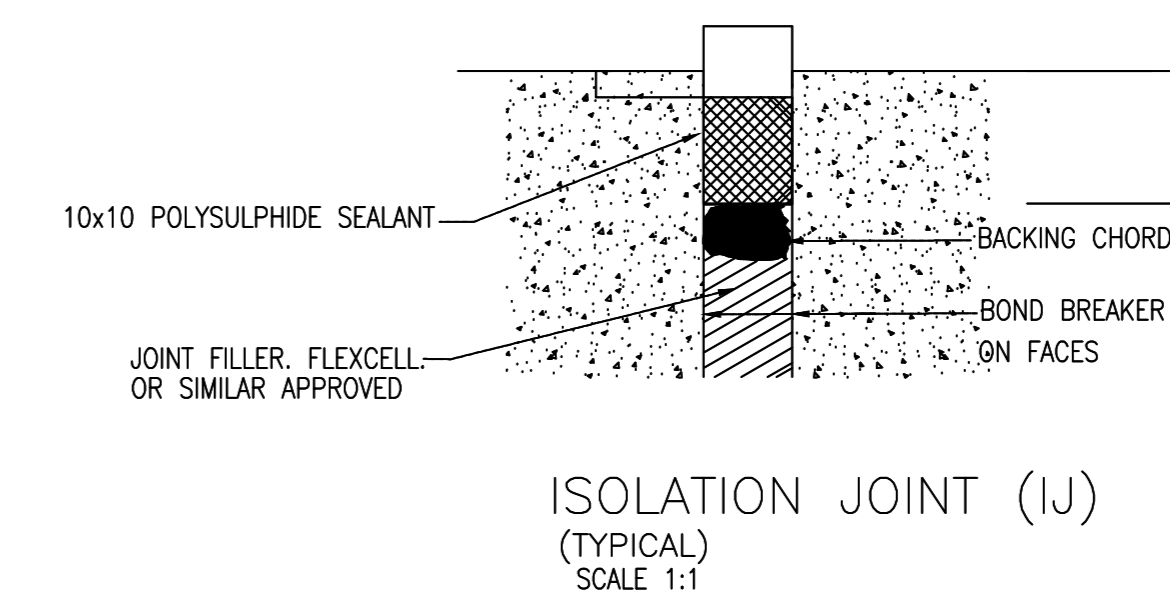
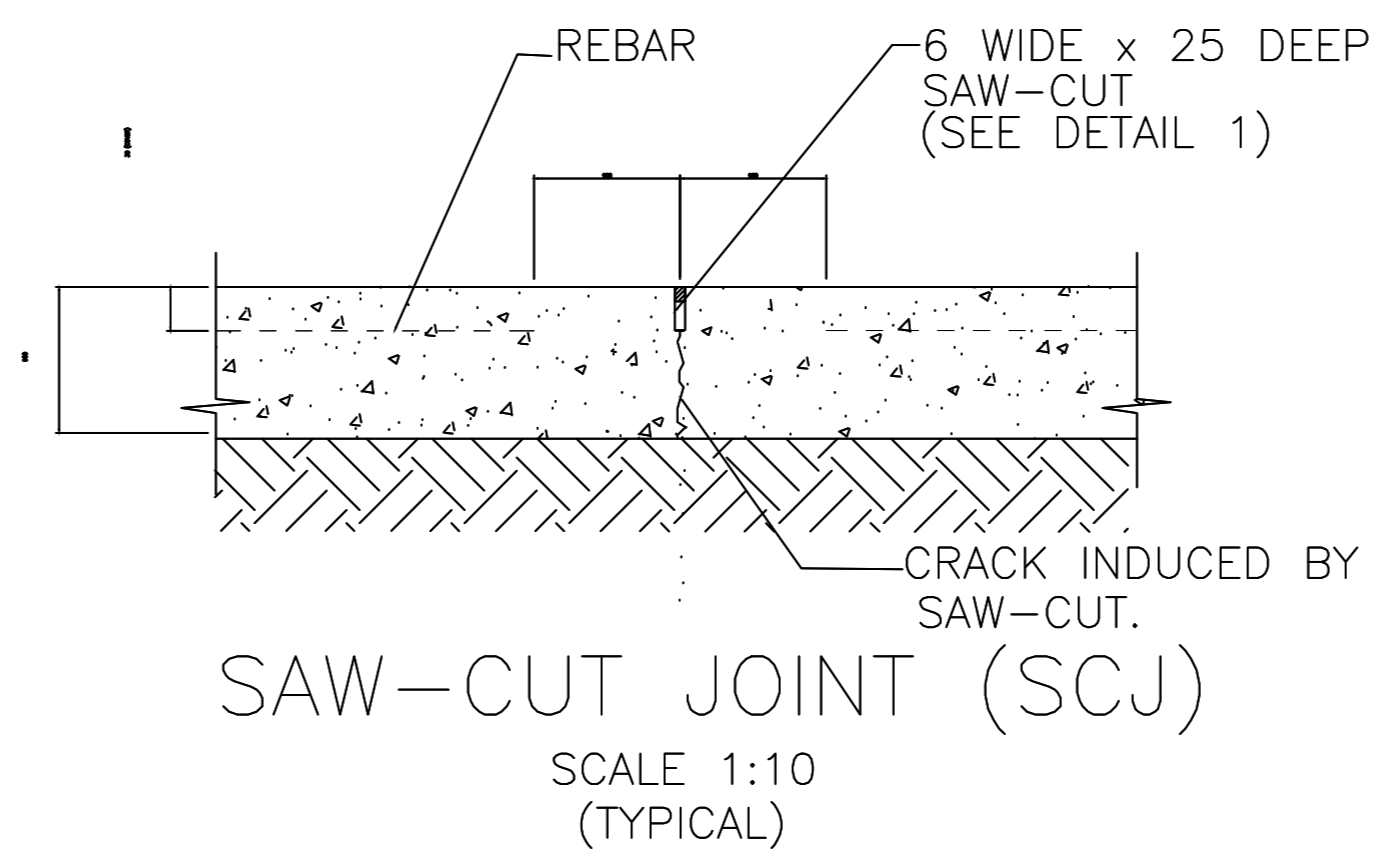
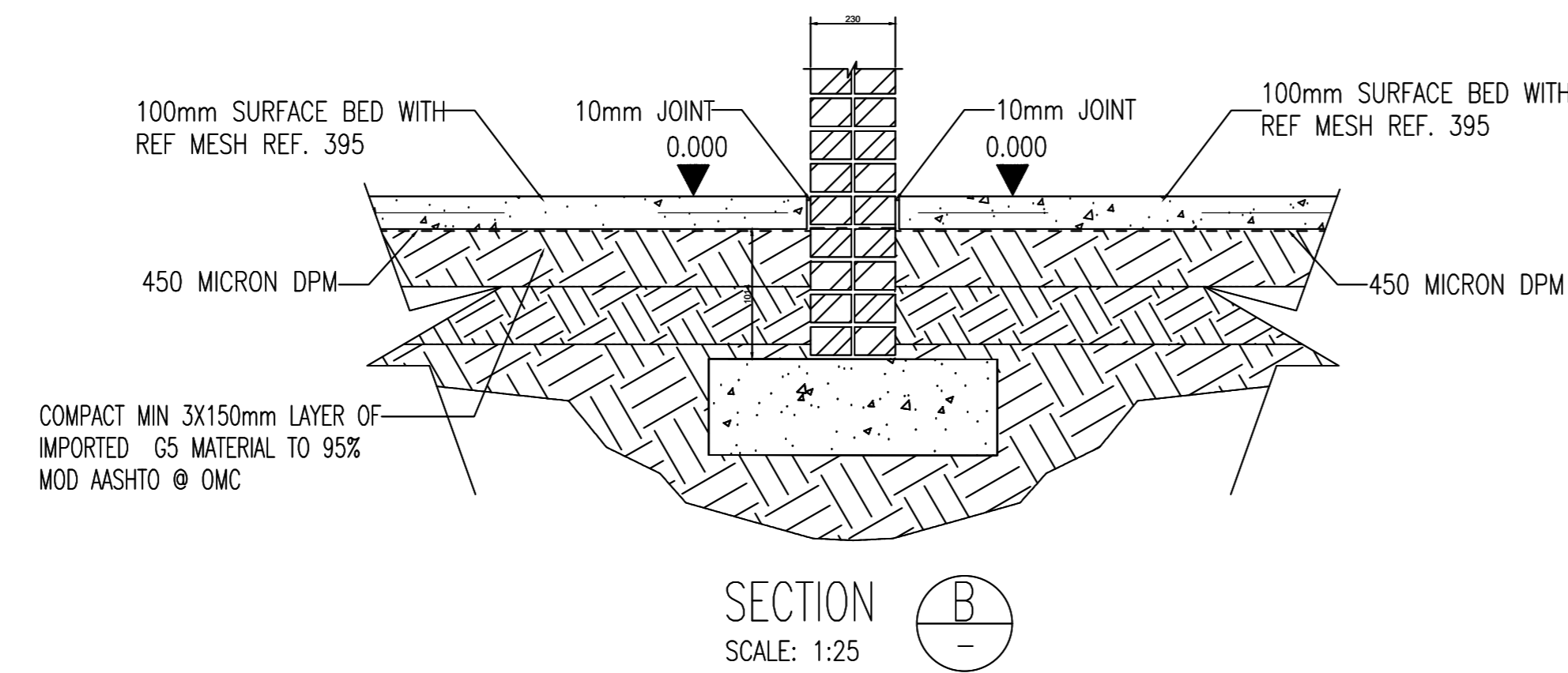
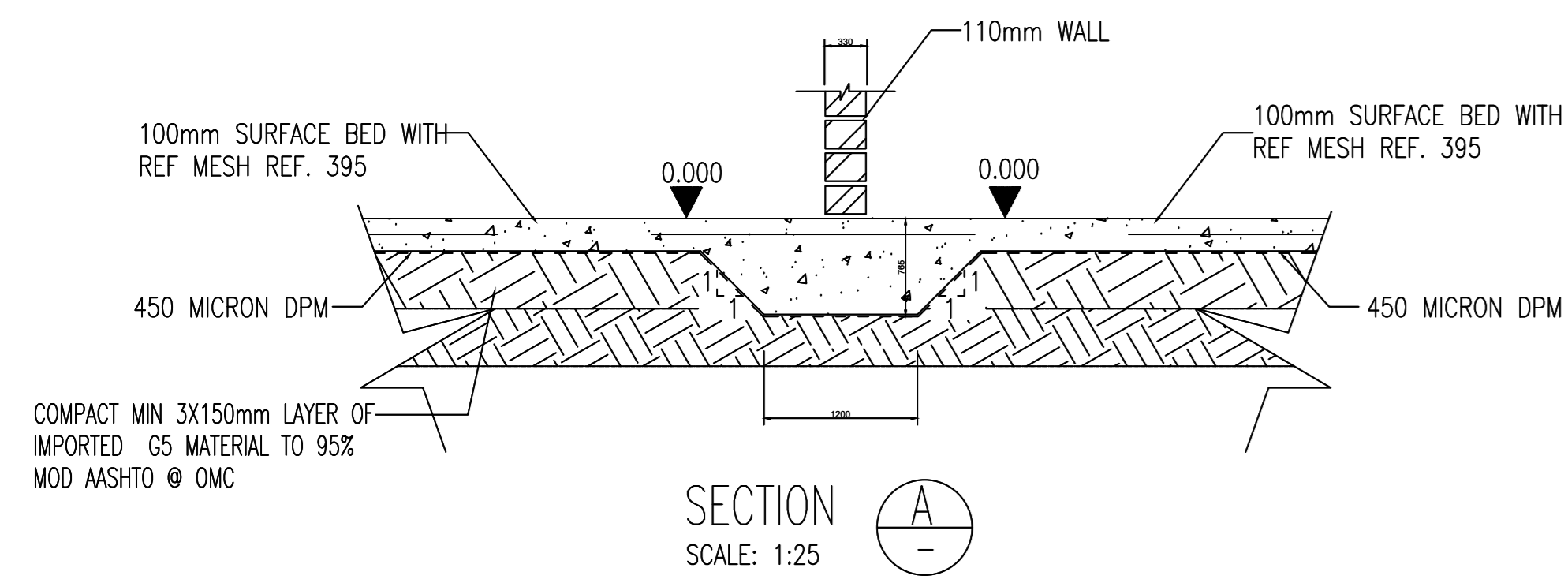
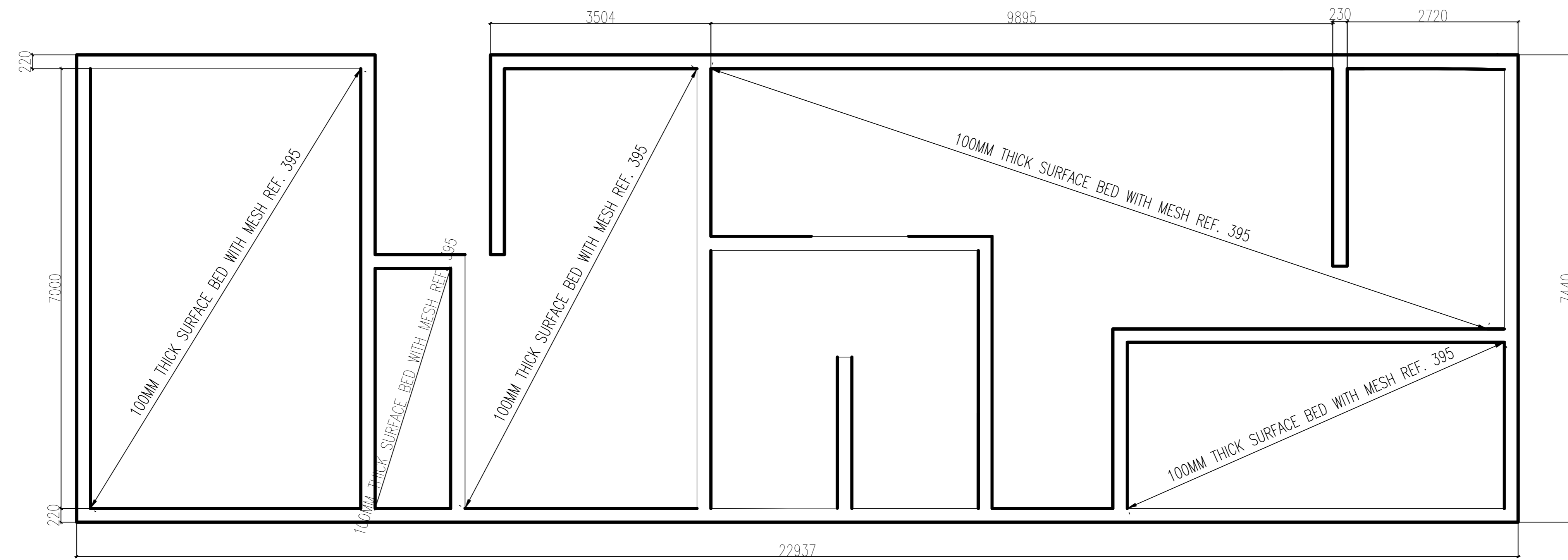

REV No	DATE	DESCRIPTION
A	03/19	ISSUED FOR APPROVAL
REVISIONS		
SIZE ON ORIGINAL DRAWING 100 mm		

INSTITUTION
WAGPOS TECHNICAL SCHOOL

SERVICE DESIGN
REFURBISHMENT

BOC	BUILDING / SITE DESCRIPTION	STAGE
A3	SITE	4

DISCIPLINE
STRUCTURAL
WORK DESCRIPTION - SUB DIVISION
ADMIN SURFACE BED LAYOUT

DATE	RESPONSIBLE PROFESSIONAL - DESIGN NAME	SIGNATURE	PR NUMBER
22/10/2019	R. SUKHLAL		200370162
DATE	RESPONSIBLE PROFESSIONAL - CO-ORDINATION		REV
22/10/2019			200370162

CONSULTANT :
CONTRACTOR :

CAD SYSTEM	AUTOCAD	962-S1-ST-C-001-A	FILE NAME
SIZE	A1	DRAWING NUMBER	REV

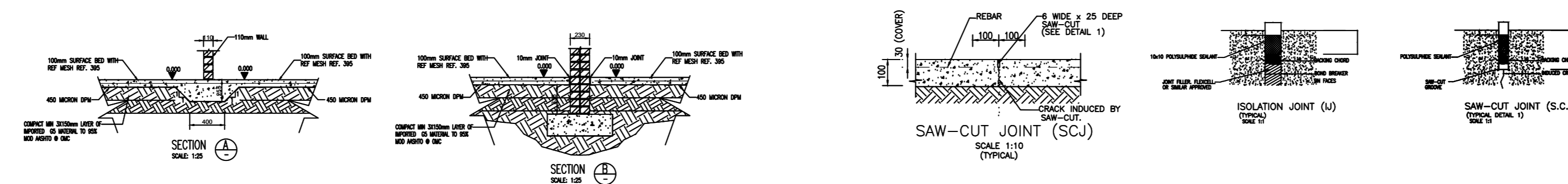
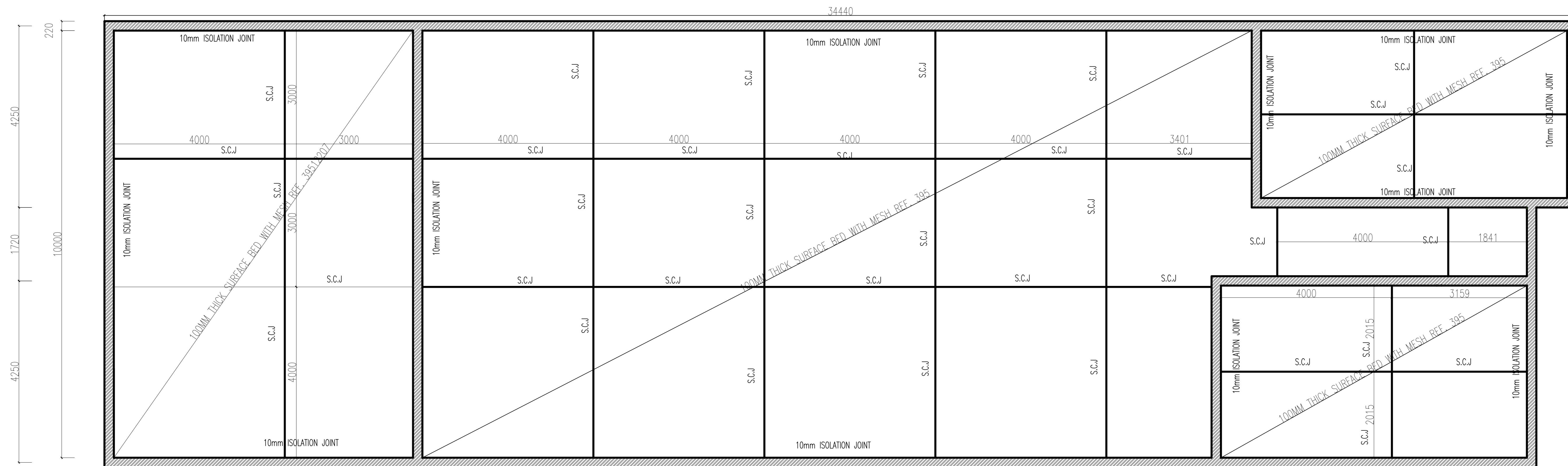

A	03/19	ISSUED FOR APPROVAL
REV No	DATE:	DESCRIPTION:

REVISIONS		

INSTITUTION
WAGPOS TECHNICAL SCHOOL

SERVICE DESIGN
REFURBISHMENT

BOC	BUILDING / SITE DESCRIPTION	STAGE
A3	SITE	4

DISCIPLINE
STRUCTURAL

WORK DESCRIPTION - SUB DIVISION
BUILDING WORKSHOP SURFACE BED

	T.MATSEKE	DRAWN
	T.MATSEKE	CHECKED
	M.NYAMUNDURU	

DATE	NAME	SIGNATURE	PR NUMBER
22/10/2019	R. SUKHLAL		200370162

RESPONSIBLE PROFESSIONAL - CO-ORDINATION
22/10/2019
CONSULTANT :
CONTRACTOR :

CAD SYSTEM	AUTOCAD	962-S1-ST-C-001-A	FILE NAME
SIZE	A1	DRAWING NUMBER	REV

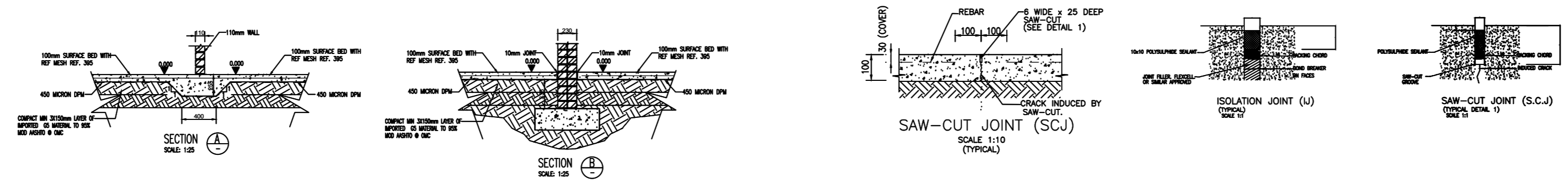
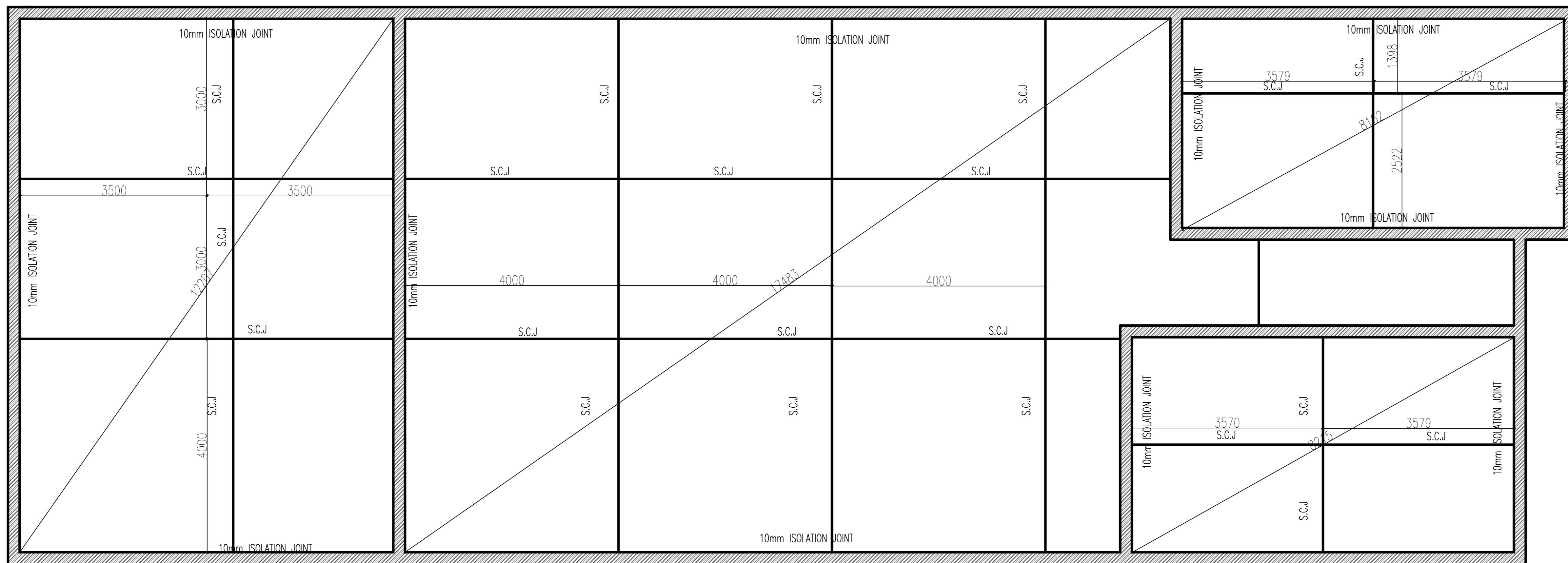

A	03/19	ISSUED FOR APPROVAL
REV No	DATE :	DESCRIPTION :

REVISIONS		

INSTITUTION
WAGPOS TECHNICAL SCHOOL

SERVICE DESIGN
REFURBISHMENT

BOC	BUILDING / SITE DESCRIPTION	STAGE
A3	SITE	4

DISCIPLINE
STRUCTURAL

WORK DESCRIPTION - SUB DIVISION
DIGITAL WORKSHOP SURFACE BED

	T.MATSEKE	DRAWN
	T.MATSEKE	CHECKED
	M.NYAMUNDURU	CHECKED

DATE	RESPONSIBLE PROFESSIONAL - DESIGN NAME	SIGNATURE	PR NUMBER
22/10/2019	R. SUKHLAL		200370162

RESPONSIBLE PROFESSIONAL - CO-ORDINATION
22/10/2019 200370162

CONSULTANT :
CONTRACTOR :

CAD SYSTEM	AUTOCAD	962-S1-ST-C-001-A	FILE NAME
SIZE	A1	DRAWING NUMBER	REV
			A

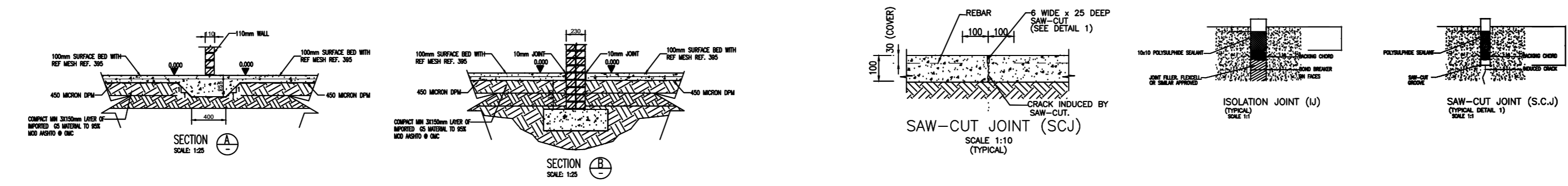
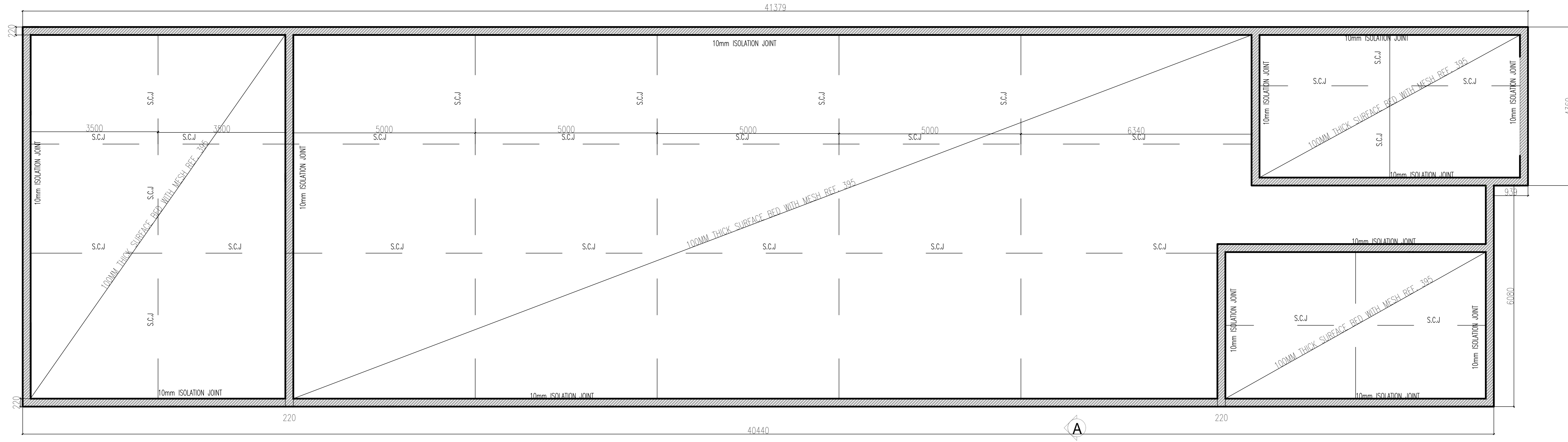

REV No	DATE	DESCRIPTION
A	03/19	ISSUED FOR APPROVAL
REVISIONS		
SIZE ON ORIGINAL DRAWING 100 mm		
INSTITUTION		
WAGPOS TECHNICAL SCHOOL		
SERVICE DESIGN		
REFURBISHMENT		
B/C	BUILDING / SITE DESCRIPTION	STAGE
A3	SITE	4
DISCIPLINE		
STRUCTURAL		
WORK DESCRIPTION - SUB DIVISION		
FITTING AND MACHINING SURFACE BED		
DRAWING DESCRIPTION		
T.MATSEKE		DRAWN
T.MATSEKE		CHECKED
1: 500		M.NYAMUNDURU
DATE	NAME	PR NUMBER
22/10/2019	R. SUKHLAL	200370162
RESPONSIBLE PROFESSIONAL - CO-ORDINATION		
22/10/2019		200370162
CONSULTANT :		
CONTRACTOR :		
CAD SYSTEM	AUTOCAD	FILE NAME
A1	962-S1-ST-C-001-A	REV
DRAWING NUMBER		A

NOTE:
ALL PAVING BLOCKS TO BE MANUFACTURED
IN ACCORDANCE WITH SABS 1058 (CLASS 30/2,0)

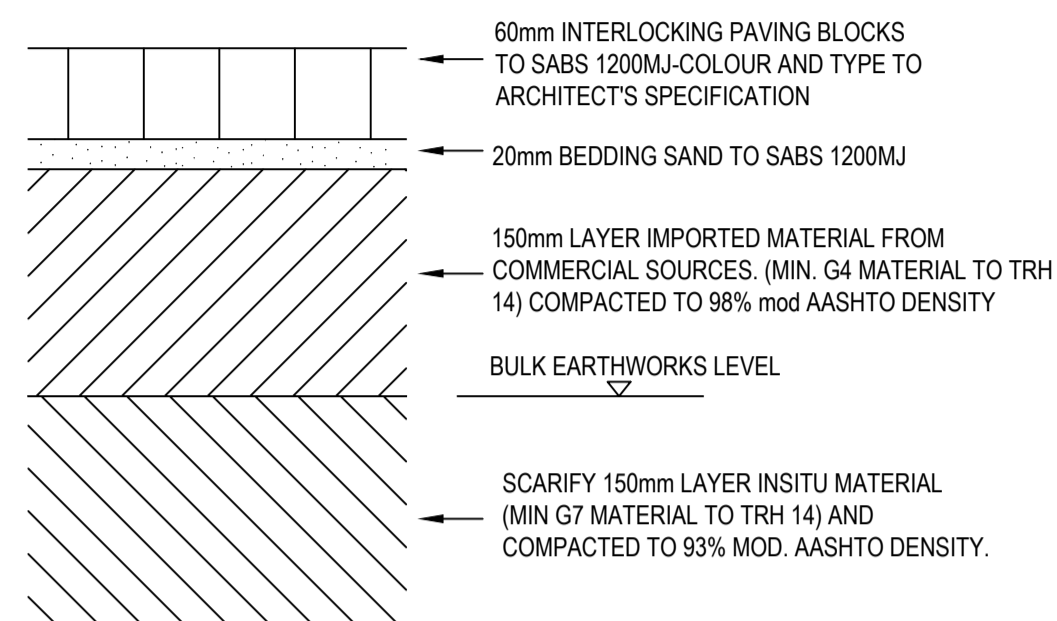

WALKWAY LAYERWORKS
SCALE 1:5

NOTE:
ALL PAVING BLOCKS TO BE MANUFACTURED
IN ACCORDANCE WITH SABS 1058 (CLASS 30/2,0)

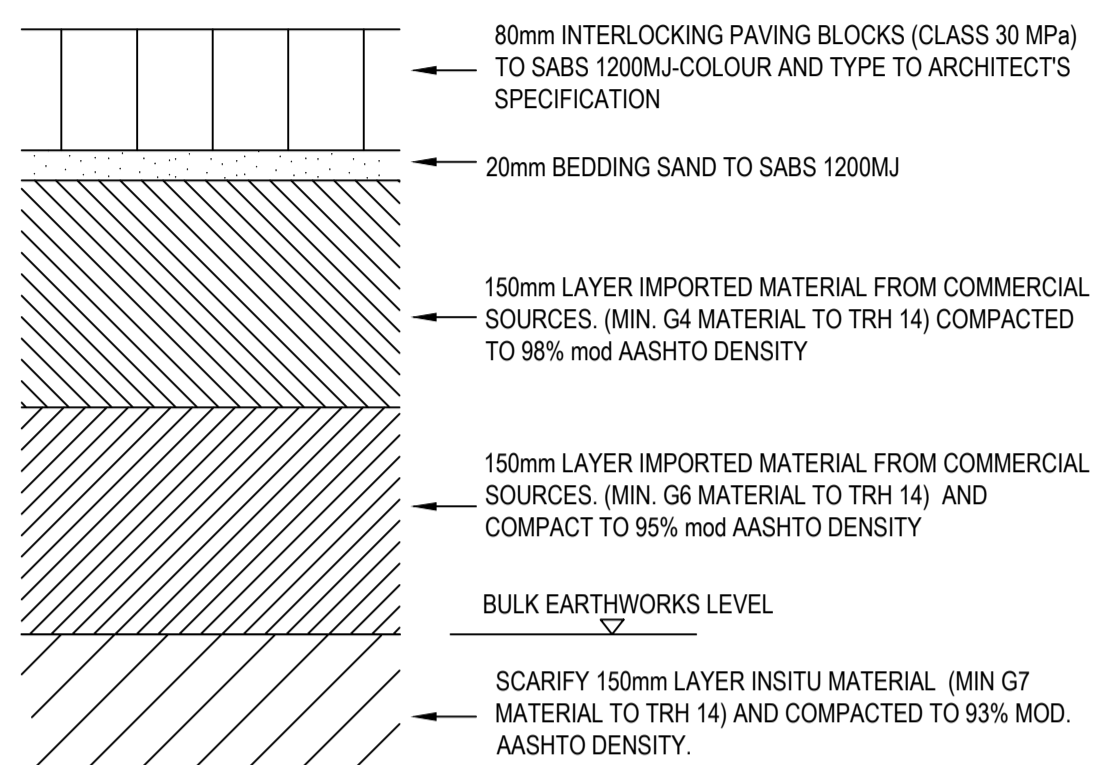

ROAD AND PARKING LAYERWORKS
SCALE 1:5

1. ALL WORK TO BE CONSTRUCTED IN ACCORDANCE WITH RELEVANT SABS 1200 SPECIFICATIONS
2. DESIGN CONTOURS AT 100mm INTERVALS
3. GROUND CONTOURS AT 500mm INTERVALS
4. ALL PARKING BAYS ARE TO BE 2.5m WIDE x 5.0m LONG UNLESS OTHERWISE SHOWN
5. ALL KERB RADII ARE TO BE 0.3m UNLESS OTHERWISE SHOWN
6. ALL THE KERBS TO BE FIG. 4 TYPE UNLESS OTHERWISE SHOWN
7. IN THE CASE OF FIG. 4 TYPE KERBING - TOP OF KERB TO BE 140mm ABOVE FINAL PAVING
8. ALL DIMENSIONS AND LEVELS REFER TO FRONT FACE OF KERB AT ROAD LEVEL
9. KERB RADII LESS THAN 1m TO BE CAST IN SITU CONCRETE
10. KERB RADII BETWEEN 1m AND 4m TO BE CONSTRUCTED IN 0.3m LENGTHS (PRECAST)
11. PAVING LEVELS TO BE READ IN PREFERENCE TO DESIGN CONTOUR LEVELS
12. FOR ALL SERVICES TRENCHES OUTSIDE OF SITE BOUNDARY - HAND EXCAVATION TO BE DONE TO ESTABLISH LOCATION OF ALL EXISTING COUNCIL SERVICES (TO BE DONE PRIOR TO CONSTRUCTION OF SERVICES WITHIN THE SITE)
13. CONTRACTOR TO CONFIRM EXISTING SITE ENTRANCE LEVELS PRIOR TO CONSTRUCTION OF ROAD LAYERWORKS
14. DENSITY TEST RESULTS ARE TO BE PROVIDED FOR ALL COMPLETE LAYERS PRIOR TO WORK ON SUBSEQUENT LAYERS COMMENCING
15. TRAFFICKING OF INTERLOCKING BLOCK PAVING PRIOR TO EDGE RESTRAINTS BEING CONSTRUCTED AND JOINTS BEING GROUTED WILL NOT BE PERMITTED
16. NO CONSTRUCTION TRAFFIC IS PERMITTED ON THE STABILIZED LAYER WITHIN THE CURING PERIOD (7 DAYS)
17. ALL COMPLETED LAYERS ARE TO BE INSPECTED AND SIGNED OFF BY THE ENGINEER PRIOR TO THE COMMENCEMENT OF THE NEXT LAYER (SUBGRADE, SUB-BASE & BASE COURSE)

GN-BS-001	BENDING SCHEDULE	0
DRAWING NUMBER	DESCRIPTION	REV

REFERENCE DRAWINGS

**DO NOT SCALE - IF
IN DOUBT, ASK**

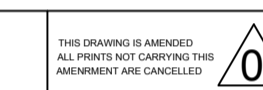

INDEPENDENT
DEVELOPMENT
TRUST
REPUBLIC OF
SOUTH AFRICA

CLIENT APPROVED _____
CLIENT'S NAME _____
CLIENT'S SIGNATURE _____ DATE _____
IMPLEMENTING AGENT _____

CONSULTANT:
AES consulting
POSTAL
AES CONSULTING
P.O. BOX 19025
FOURWAYS EAST
JOHANNESBURG
2008
CONTACT PERSON:
MR. R. SIKHULU
TEL No: (011) 234 0711
FAX No: (086) 218 8259

0	FOR CONSTRUCTION	K.M
REV	DATE	DESCRIPTION
		CHKD

PROJECT TITLE:
WAGPOS TECHNICAL SCHOOL

DRAWN TITLE:
**ROAD AND WALKWAY
DETAILS**

DRAWN STATUS:
TENDER

DESIGNED: C.M. DRAWN: C.M. CHECKED: K.M. INCEPTION DATE: 2016
SCALE: AS SHOWN

APPROVED: _____
PROJECT ENGINEER'S SIGNATURE
PROJECT ENGINEER'S NAME/PROF REG No: _____ DATE: _____
DRAWING NUMBER: _____ DRG SIZE: **A1**

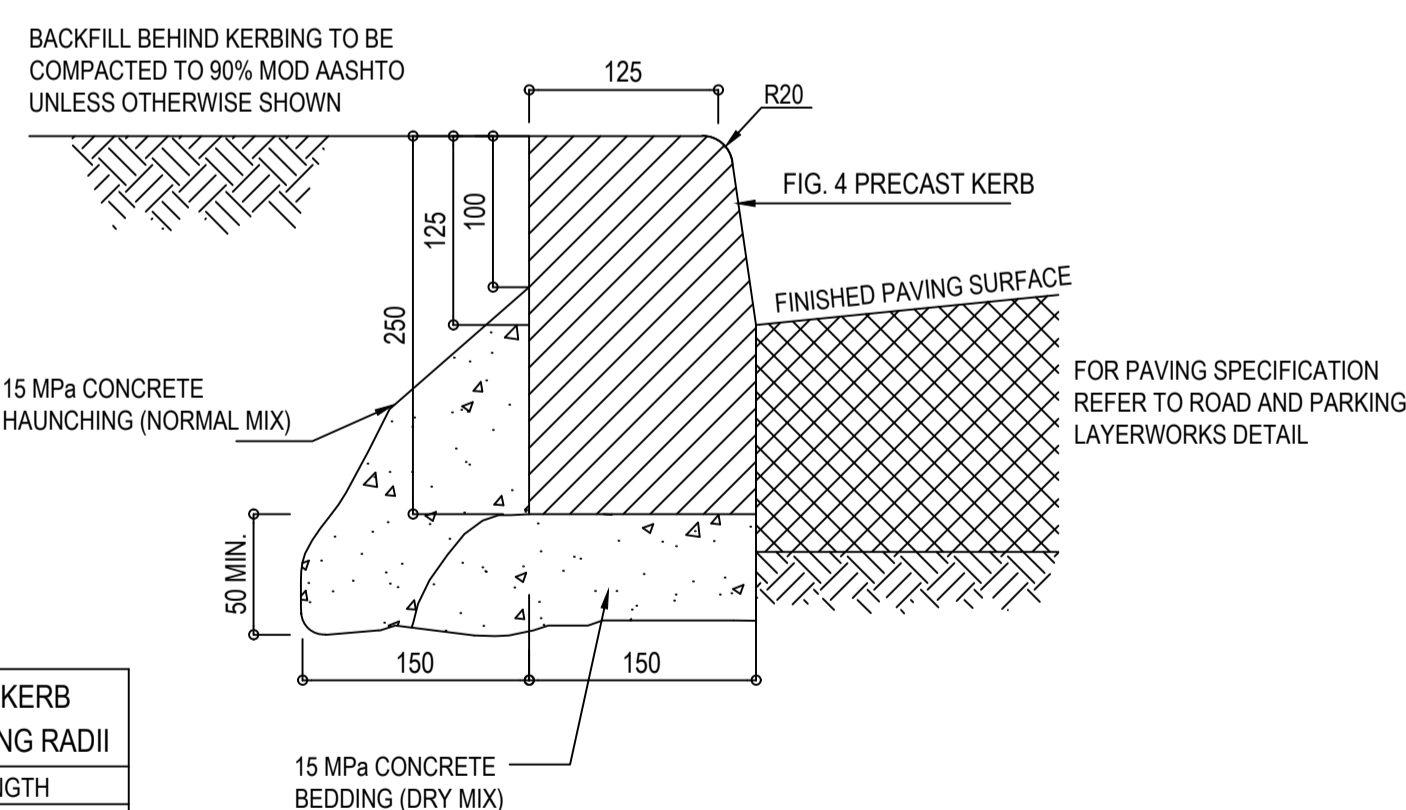
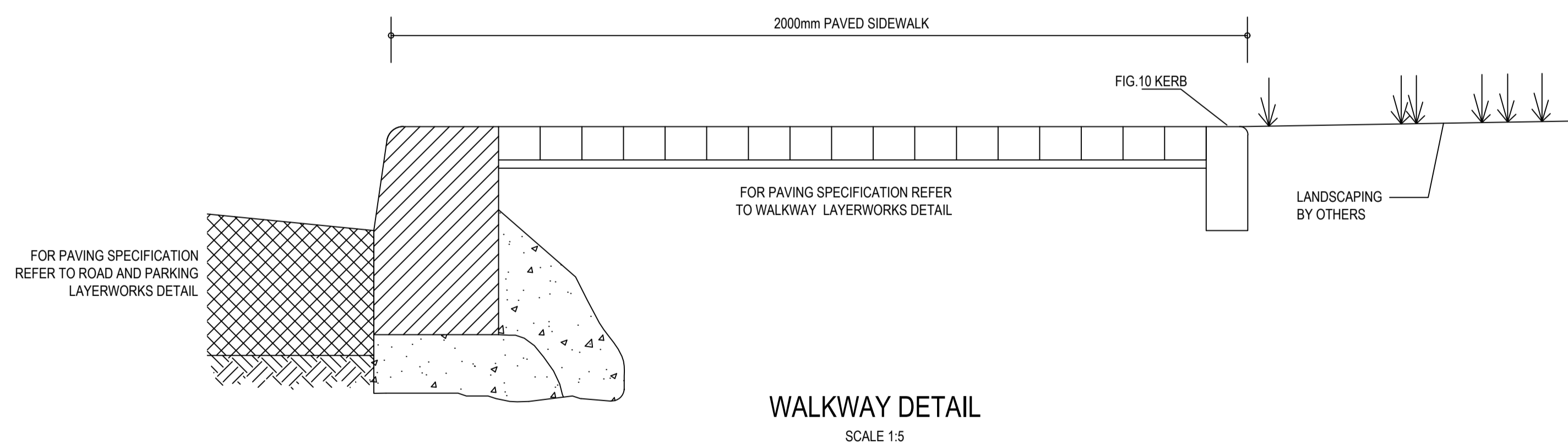

FIG 4 PRECAST KERB
SCALE 1:5

LENGTH OF PRECAST KERB SECTIONS FOR VARYING RADII	
RADIUS	MAX KERB LENGTH
0-1m	CAST INSITU
1-4m	0.3 m
4-20m	0.5 m
20m -	1.0 m

NOTE
1: ALL KERBING TO BE CONSTRUCTED TO SABS 1200 MK
2: HAUNCHING AT JOINTS ONLY



WALKWAY DETAIL
SCALE 1:5

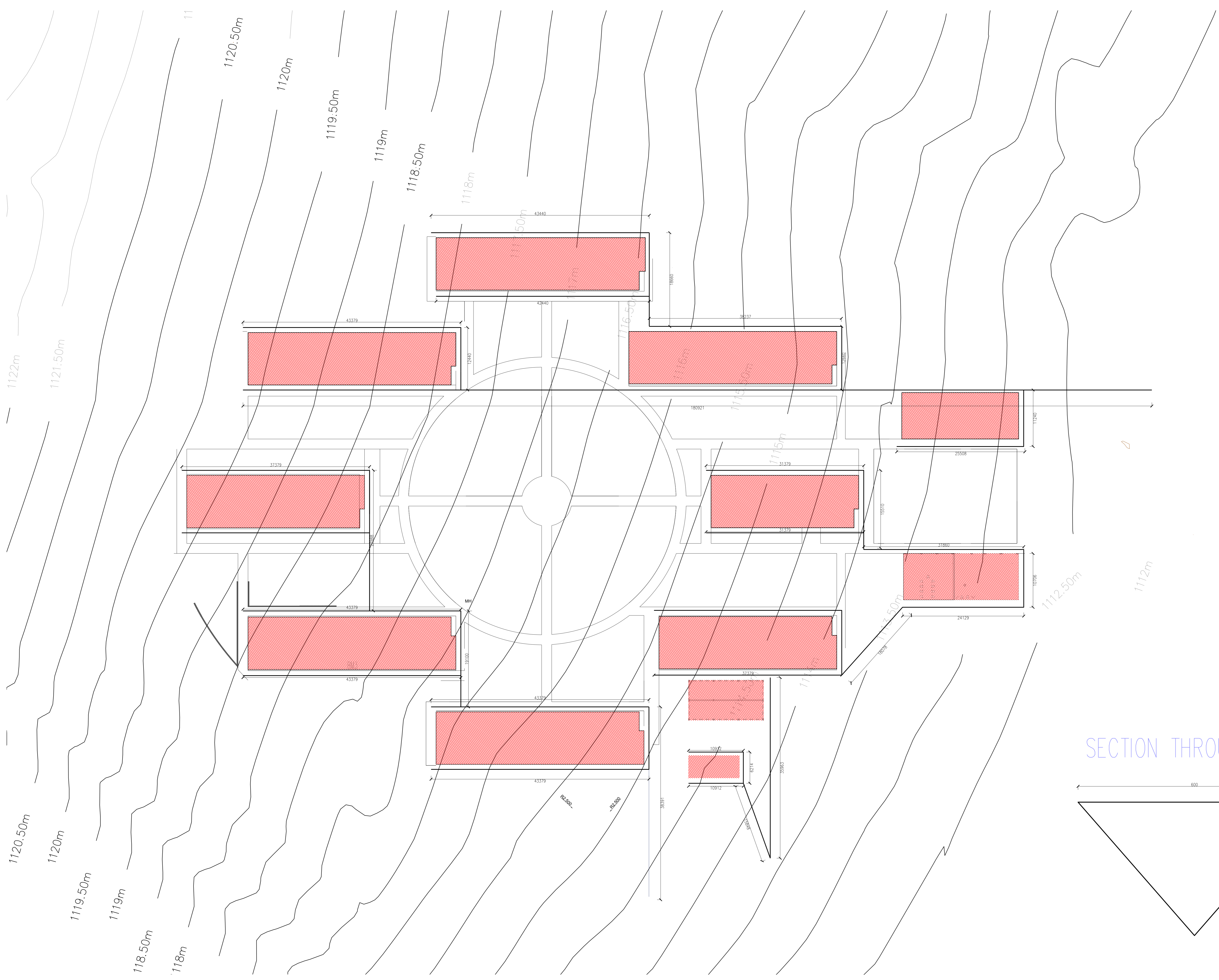

SECTION THROUGH CHANNEL

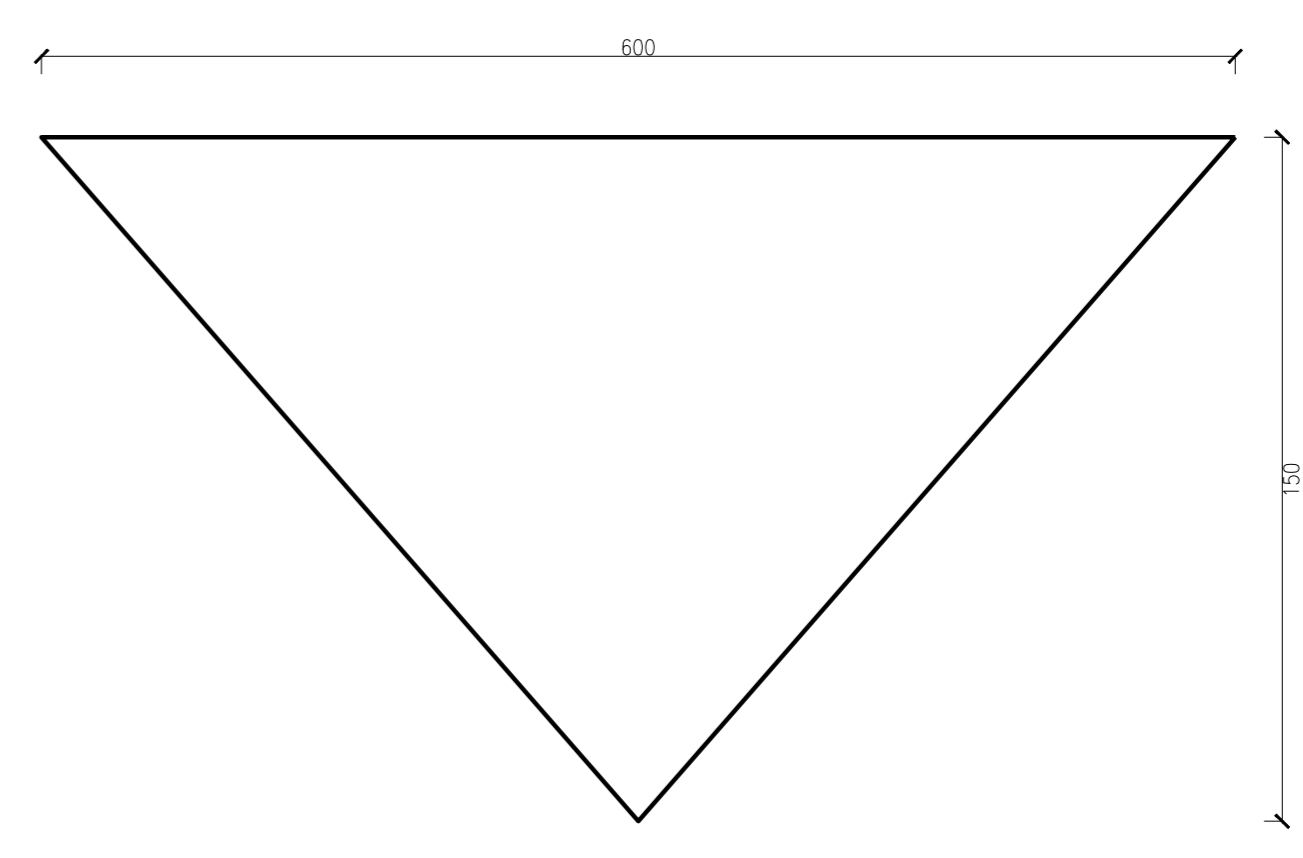

- NOTES:**
1. CONTRACTOR TO CONFIRM INVERT LEVEL OF EXISTING MANHOLE AT CONNECTION POINTS, PRIOR TO CONSTRUCTION OF SEWER PIPES .
 2. ALL WORK TO BE DONE IN ACCORDANCE WITH RELEVANT SANS 1200 SPECIFICATIONS AND JW STANDARDS.
 3. ALL SEWER PIPES TO BE uPVC CLASS 34, UNLESS OTHERWISE SHOWN
 4. ALL BEDDING TO BE CLASS 'C' UNLESS OTHERWISE SHOWN
 5. PIPE TRENCHES TO BE BACKFILLED IN 150mm LAYERS OF SELECTED MATERIAL AND COMPACTED TO 93% MOD. AASHTO
 6. BEDDING TO BE COMPACTED TO 90% MOD. AASHTO
 7. PIPES TO BE LAID CROWN TO CROWN
 8. ALL WORK TO COMPLY WITH LOCAL AUTHORITY REQUIREMENTS
 9. THE CONTRACTOR IS TO SEARCH FOR AND CONFIRM POSITIONS AND DEPTHS OF ALL SERVICES BEFORE COMMENCING WORK. PROTECTION OF SERVICES DURING CONSTRUCTION IS THE CONTRACTORS RESPONSIBILITY
 10. ALL RELEVANT WAYLEAVES TO BE OBTAINED BY CONTRACTOR PRIOR TO CONSTRUCTION COMMENCING
 11. SERVICE EXCAVATIONS EXCEEDING 1.5m DEPTHS MUST BE SUFFICIENTLY SHORED OR CUT BANKS TO BE PROVIDED AT A 1:1 MINIMUM SLOPE UNLESS OTHERWISE SHOWN.

REV No	DATE	DESCRIPTION
A	03/19	ISSUED FOR APPROVAL
REVISIONS		
SIZE ON ORIGINAL DRAWING 100 mm		
INSTITUTION		
WAGPOS TECHNICAL SCHOOL		
SERVICE DESIGN		
REFURBISHMENT		
ROC	BUILDING / SITE DESCRIPTION	STAGE
A3	SITE	4
DISCIPLINE		
CIVIL		
WORK DESCRIPTION - SUB DIVISION		
SEWER		
DRAWING DESCRIPTION		
LAYOUT PLAN		
T.MATSEKE		DRAWN
T.MATSEKE		CHECKED
1: 500		MNYAMINDURU
RESPONSIBLE PROFESSIONAL - DESIGN		PR NUMBER
DATE	NAME	SIGNATURE
22/10/2019	R. SUKHLAL	200370162
RESPONSIBLE PROFESSIONAL - CO-ORDINATION		
22/10/2019		200370162
CONSULTANT :		
CONTRACTOR :		
CAD SYSTEM	AUTOCAD	962-S1-ST-C-001-A
SIZE	DRAWING NUMBER	FILE NAME
A1		A

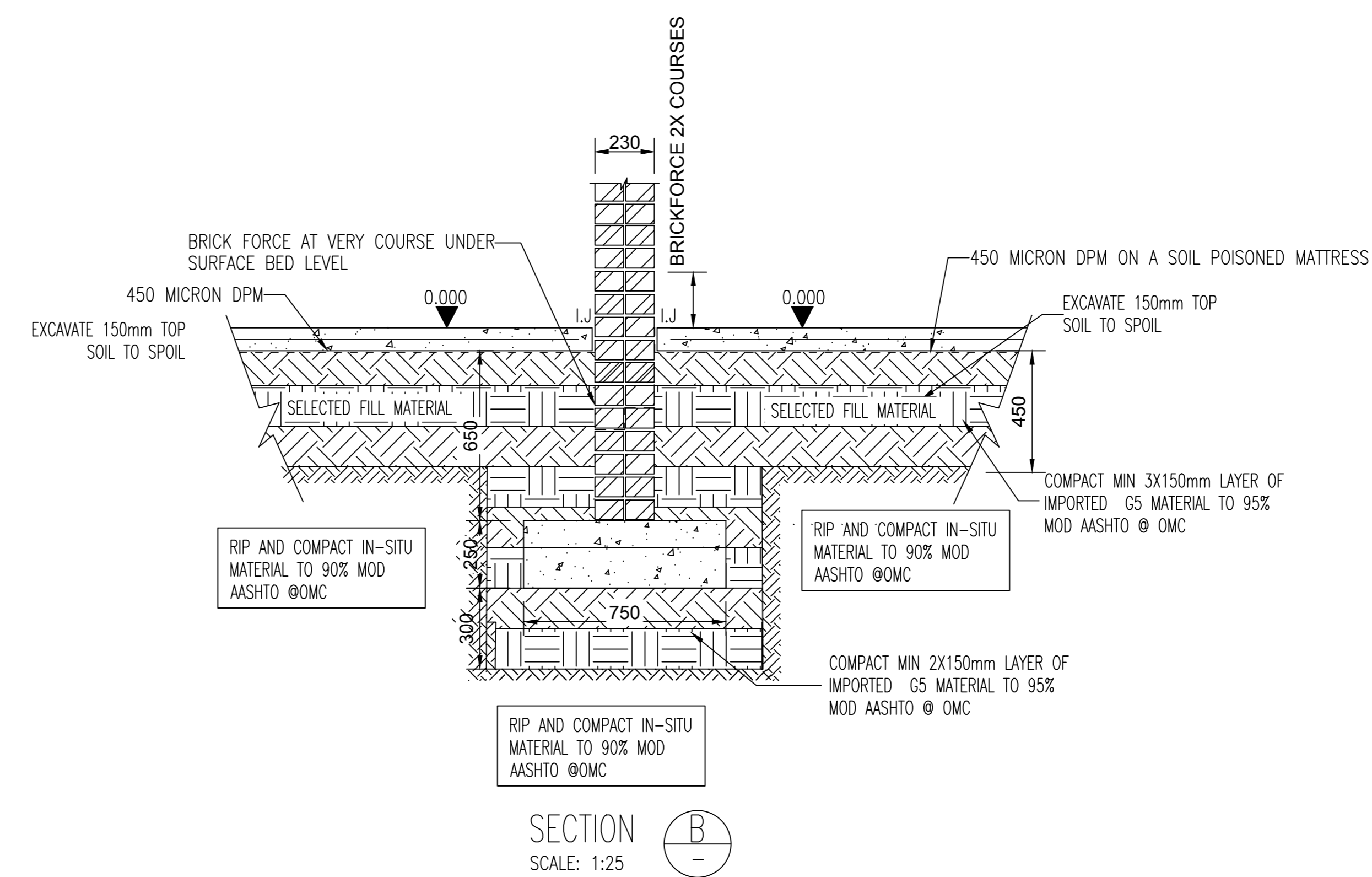
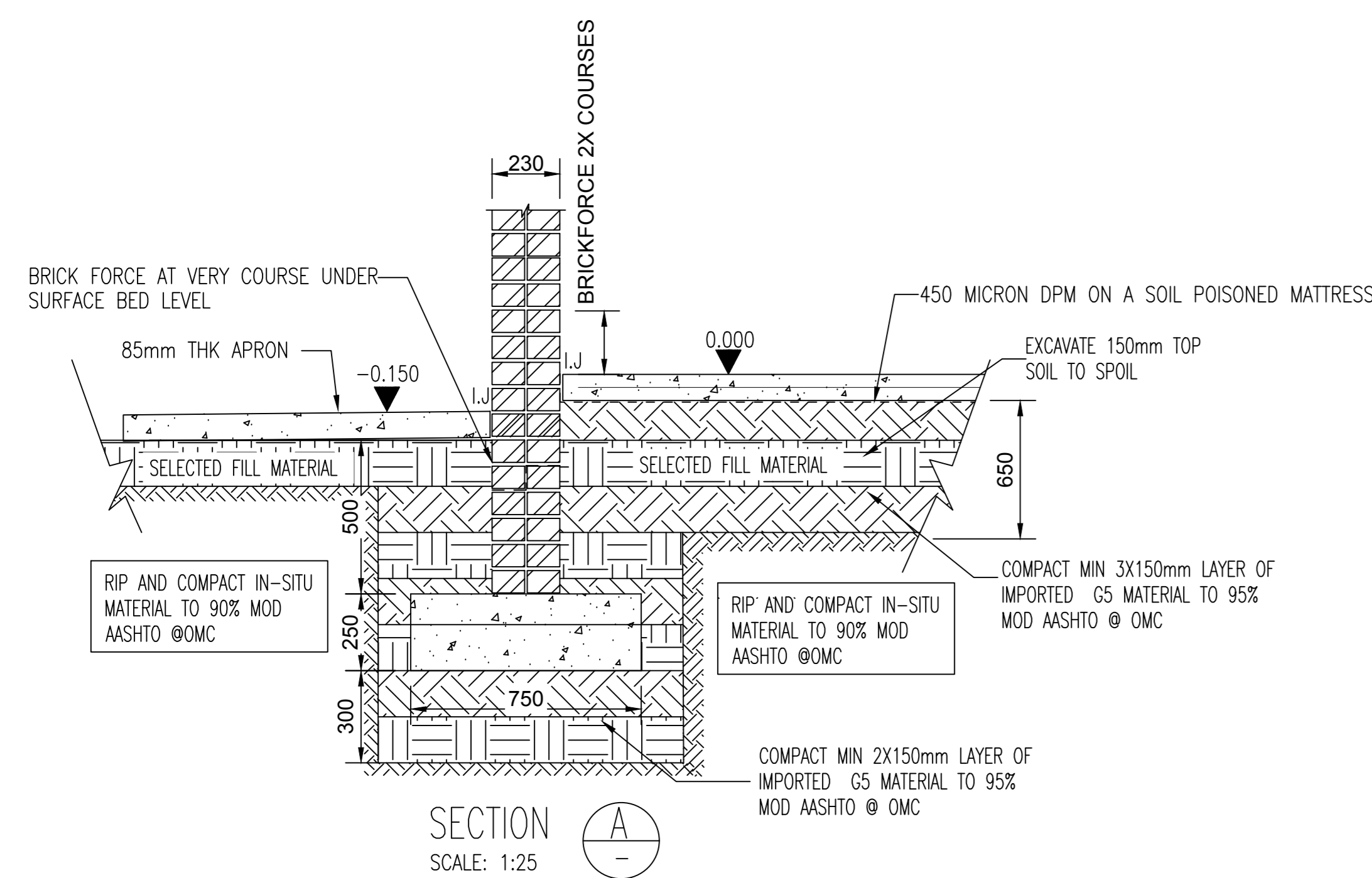
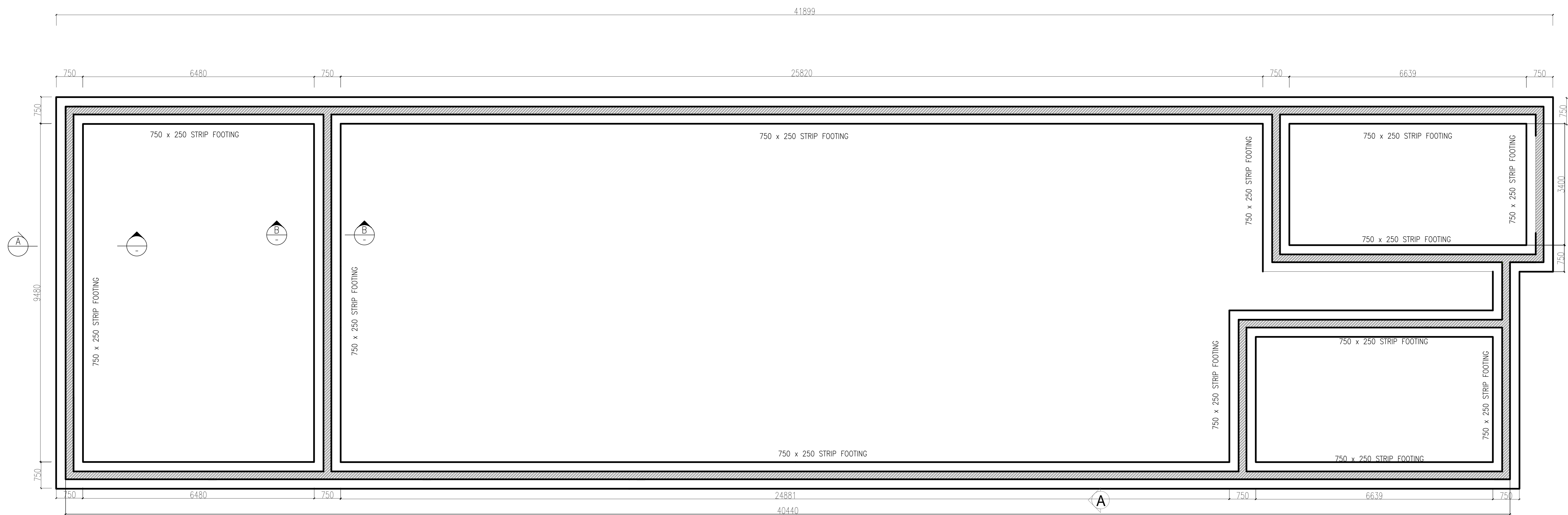

REV No	DATE	ISSUED FOR APPROVAL	DESCRIPTION
A	03/19		
REVISIONS			
SIZE ON ORIGINAL DRAWING 100 mm			
INSTITUTION			
WAGPOS TECHNICAL SCHOOL			
SERVICE DESIGN			
REFURBISHMENT			
BOC	BUILDING / SITE DESCRIPTION	STAGE	
A3	SITE	4	
DISCIPLINE			
STRUCTURAL			
WORK DESCRIPTION - SUB DIVISION			
WOODWORK FOUNDATION LAYOUT			
DRAWING DESCRIPTION			
1: 500		T.MATSEKE	DRAWN
22/10/2019		M.NYAMUNDURU	CHECKED
DATE	NAME	SIGNATURE	PR NUMBER
22/10/2019	R. SUKHLAL		200370162
22/10/2019		200370162	
CONSULTANT :			
CONTRACTOR :			
CAD SYSTEM	AUTOCAD	962-S1-ST-C-001-A	FILE NAME
A1			A